

STATE OF HAWAII
DEPARTMENT OF TRANSPORTATION
AIRPORTS DIVISION / LIHUE DISTRICT
Firefighter Station & Duty Uniforms
10/01/24

Scope of Work

Provide a Request for Proposal (RFP) to establish a Firefighters Uniform price list of goods and services on an as needed basis for the Airports Division, Kauai Districts Aircraft Rescue Firefighting Unit. Contractor shall have an established retail outlet or place of business with a facility or facilities on the island of Oahu. Services shall not exceed budgeted amount \$50,000 which includes applicable fees, taxes and extend more than one calendar year. Details of services are attached.

Brand or Trade Name

Whenever a brand or manufacturer's name, designation or material appears in connection with the specified item, such name or designation indicates the standard of quality desired, and the reference shall follow applicable trademark or Copyright laws.

The Officer-In-Charge (O-I-C)

State of Hawaii, Department of Transportation - Airports Division, Airports Fire Chief or his designate. Ph. 808-241-3855

Payments

The Airport will make payments with an approved Purchase Order (PO) or by pCcard. Any remaining portion thereof shall be the responsibility of the ARFF personnel.

Delivery/Received Dates

All authorized purchases will be scheduled and arranged for picked up by ARFF personnel once payment is made in full.

Airport Location

Lihue Airport

Attn: Airport Managers Office

3901 Mokulele Loop #6

Lihue, HI. 96766

Minimum Specifications

The type, color, design, quality, and performance of material specified shall be equal to the existing uniforms being used locally by the Honolulu Fire Department (HFD). It shall be the Contractor's responsibility to ensure that the uniforms being offered match with the existing Workrite Uniform Company:

1. Navy Duty Uniform Short Sleeve Shirt: Workrite FSF2 or approved substitute.
2. Navy Fire Fighter Pants: FP52 or approved substitute.
3. Navy Duty Uniform Base Layer Fire Resistive T-Shirts.
4. Duty Uniform Jacket, Polyester
5. Duty Uniform Cotton T-Shirts (Short Sleeve)
6. Duty Uniform Cotton T-Shirts (Long Sleeve)
7. Navy Duty Uniform Board Shorts
8. Navy Duty Uniform Athletic Shorts

If in the event the uniforms being offered does not match in type, color, design, quality, or performance; to include, but not limited to the rate of fading after multiple washings, wear, and durability; the Contractor shall be responsible to replace all the uniforms provided, used or new, at the Contractors own expense with five (5) days of notification.

Additional Services.

Fittings/Alterations

The Contractor, based on their professional experience, may initiate a discussion with the ordering ARFF Personnel to determine whether the wearer, based on past experience, need to have basic alterations of the duty uniform shirt, trouser, or jacket and what, if any, alterations would be needed. Any errors or costs involved in the initial judgment to recommend alternations or corrections of the uniform situation, shall be the responsibility of the Contractor, at no additional cost to the Airport.

To expedite the general fitting process, the Contractor shall have a complete set of all sizes for the various groups of uniform, or at a minimum, the most general sizes in each garment type to be provided.

The Contractor shall provide an initial fitting for the individual ARFF employee at the time that the ARFF Personnel places an authorized order to purchase the uniforms. The individual ARFF employee shall be allowed, when trying on the uniform for the initial fitting, to request a maximum of one (1) trouser hem alteration to each garment for a proper fit.

When the ARFF Personnel is contacted to pick up their finished garments, the Contractor shall offer the Personnel, one (1) final fitting to ensure a proper fit before the uniform is accepted.

If women's sizes are not available, a minimum of one (1) fitting for custom tailoring shall be made available to the female personnel, at no additional cost to Airport or ARFF personnel.

The Contractor shall be responsible to inform the ordering ARFF Personnel that the cost of any alterations after they sign to accept any uniform item shall be the responsibility of the ordering ARFF Personnel. However, if the Contractor is unable to obtain a satisfactory fit that is acceptable to the wearer after the one (1) alteration allowed, the Contractor shall inform the ordering ARFF Personnel that no additional attempts to fix the uniform can be made without further approval from the OIC or his/her representative at (808) 241-3855.

Nomex or approved substitute thread shall be used for any and all alterations, including hemming.

The cost to put in any gussets, as needed, on the shorts or shirts to ensure proper fit, shall be included in the unit price.

All garment parts must be properly cut to avoid puckering after laundering.

All hems shall be blocked at the front opening, turned, and single needle stitched.

The garment shall not have any incomplete sewn hems or loose threads.

Stitching must be of proper tension and size and shall be maintained throughout the garment to avoid loose stitching, which may result in unraveling or seam failure. Tight stitching shall also be avoided, which may result in bunching or gathering.

The Contractor shall make minor repairs to the garments at no additional cost to the Airport, within the timeframe specified.

The material quality, construction and appearance shall be without flaws and maintained consistent with each garment.

Any metal fasteners or adornments must not be exposed to or come in contact with the wearer's skin.

Each design, letter, and punctuation mark shall have "full" threads embroidered onto the material so as not to show the background color of the fabric and be neatly and professionally sewn by the Contractor.

Each design, letter and punctuation mark shall have visually correct placement, and be evenly spaced with each letter having clean and separate "breaks" between each piece. The threads shall be contained within the backing material and edging must not be frayed or loose.

The name and/or the rank and stars shall be embroidered directly on to the uniform material.

Re-embroidery or monogramming due to Contractor clerical error or poor-quality sewing of lettering shall be provided by the Contractor, at no additional cost to the Airport.

All silk screening shall be done in a professional manner and shall utilize the highest quality and best standard industrial practices when producing and screening the garments specified. Any screening that is crooked, has blurry designs, is not visually centered or artistically pleasing, of poor quality, or with any type of misprint, shall be rejected.

The Contractor must fit each ordering ARFF employee and provide an initial hemming of the pants, at no additional cost to the Airport.

A request may be made from the Contractor to have a slanted hem – with one (1) leg longer or shorter than the other side. If done, the slanted hem shall be at no additional cost to the Airport.

The Contractor shall provide the embroidered names and patches, for the uniforms herein as part of the Contract unit prices for the uniform shirts and other apparel.

The Contractor shall charge the ARFF Personnel requesting additional services at listed pre-approved amount.

All garments and other items being offered shall meet or exceed when applicable all National Fire Protection Association (NFPA) and American Society for Testing and Materials (ASTM) requirements for the intended use of the garments being offered. The Airport reserves the right to request proof of compliance prior to award. Failure to provide proof of compliance shall cause for rejection of the offer.

Extra Work.

No work of any kind in connection with the work covered by the specifications shall be considered as extra work or entitle the Contractor to extra compensation, except when work is ordered in writing by the OIC and specifically referred to as extra work.

The Contractor shall provide a listing of additional services available to supplement these specifications, along with the fees, for work such as: lengthening of pants legs, tapering sides of shirts, shortening sleeves, pant waist alteration, attaching of service stars, monograms or any other work that requires additional attachment, disassembling or detaching sections of the garment, repair, or other replacement.

The Airport reserves the right to pay for additional services by Special Order and shall be indicated on an approved purchase order (PO), or pCard,

Should additional requests be made of the Contractor, or a service is requested that does not appear to be covered under this specification, the Contractor shall contact the OIC or his/her representative at (808) 241-3855.

The Airport shall not be responsible for any additional work outside the scope of work as listed in the Specifications that is requested by the individual ARFF Personnel. The OIC must approve of this additional request.

Embroidery:

The name and rank shall be embroidered directly on the uniform material. For the embroidered name and rank, the letters shall be centered over the right pocket of the dress uniform shirts and a designated area on the right chest for uniform jackets. The lettering shall comply with the current lettering used by HFD.

The lettering shall be 3/8 in. high, in Helvetica type style, with the letters evenly spaced. The member's rank shall be 1/4 in. above the top of the pocket.

The ARFF Personnel's name shall consist of the first initial, a period after the first initial and the full last name shall be 1/4 in. above the rank. All letters shall be in capitals. However, should the ARFF Personnel state that the lower-case letters must be used in order that the name be spelled correctly (i.e., a name such as "DeAguiar", where the "e" is not in caps), the member's name may be spelled using lower case letters where appropriate.

Any question as to the appropriate lettering embroidery style to use or spacing of the letters may be directed to the authorized OIC for clarification.

The embroidered lettering color and shade shall be determined prior to the issuance of the approved purchase order by the OIC.

The Airport reserves the right to add or remove any embroidery required, to include but not limited to name and rank, at no additional cost to the Airport.

Optional Service Stars:

Shall be embroidered directly on to the shirt or jacket if requested, with two (2) points down and centered 1/2 inch above the personnel's name. Stars shall be worn in a straight line and shall be centered and spaced 3/4 inch apart, from center to center. If six (6) or more stars are requested, a second row of stars shall be embroidered with two (2) points down and centered 1/4 in. above the first row of five (5) stars.

Lettering, and/or optional service stars shall be done in yellow for the ranks of Captain and below and gold for all Chief Officers. The Airport will provide 75% of costs and 25% shall be at ARFF personnel expense.

Item No. 1: “Navy” Fire Resistant Duty Uniform Shirts (Short Sleeve)

Men’s 4.5 oz/yd² Nomex IIIA or approved substitute Fire Fighter Shirt (Short Sleeve).

The Fire Fighter Short Sleeve Shirt shall be a dress style shirt with a front placket using decorative buttons and hidden snap fasteners for the closure to allow for quick removal. The Fire Fighter shirt shall have two military creases on the front of the shirt and three military creases on the back of the shirt.

The shirttail length shall be proportionate to the shirt size and long enough to allow ARFF personnel to raise their hands above their head and have the shirttail remain in the trousers. An optional service can be selected by the ordering ARFF personnel to have a longer shirt tail length (2” or longer) and/or proportionate length sleeves for the garment. The charge for this service shall be added to the individual shirt size price and as specified in Appendix C. Adding fabric to an existing garment shall not be acceptable.

Certification and Compliance.

Garment shall be ISO 9001 certified. Fire Fighter shirts made from Nomex IIIA (4.5 oz/yd²), or approved substitute fabrics shall meet or exceed the performance requirements of NFPA 1975, Standard on Emergency Services Work Clothing Elements. These garments shall meet or exceed the requirement of OSHA Standard 1910.269: “Electric Power Generation, Transmission, and Distribution; Electrical Protective Equipment (Maintenance Standard)”, Federal Register, Volume 59, No. 20, and CAL/OSHA General Industry Safety Orders

(GISO), Title 8. The shirt shall be tested in accordance with Federal Test Standard 191, Method 5903.2.

Materials.

The following arc ratings apply to these garments:

<u>Fabric</u>	<u>Nominal wt.</u>	<u>Arc Rating</u>
Nomex IIIA or approved substitute	4.5 oz/yd ² or approved substitute	4.1 cal/cm ² or approved substitute

Fabric:

The shirt shall be manufactured with Nomex IIIA, or approved substitute fabric made from DuPont Nomex IIIA or approved substitute fiber. The fabric shall be treated with a wickable finish to enhance absorbency and improve comfort.

Findings:

The thread size shall be 45/3 or equivalent to ensure adequate seam strength and garment integrity. The color of the thread shall match the fabric. The thread for seaming and stitching shall conform to MIL-T-43636.

Buttons used on the shirt will be made of molded polyester, size 24 ligne.

The snap fasteners shall be heavy-duty industrial grade and made of solid brass with nickel plating. All snaps shall be applied such that no metal from the snaps will be in contact with the skin.

Garment Construction:

Garments shall be constructed to maximize the wear life of the garment. Proper stitching, reinforced stress areas, and the highest quality construction features shall be used. All garment parts must be properly cut to avoid puckering after laundering and to give the best appearance. All stitching must be of proper tension and size.

Stitches and Seams:

All stitching shall conform to Federal Standard 751 (FED-STD-751A). All stitch types shall be sewn with a minimum of 8 and a maximum of 10 stitches per inch. The thread tension shall be maintained to eliminate loose or tight stitching.

Chest Pockets:

Each shirt shall have two chest pockets measuring 5 ½" wide by 6 ¾" deep at the bottom point of the pocket. Both pockets shall have a flap secured with a hook and loop closure. Each pocket shall have a decorative button with the left pocket containing a pencil slot. Pockets and flaps shall be set with double-needle lock stitching. All corners and stress areas shall be reinforced with bartack stitches.

Sleeves:

The sleeves shall be one-piece construction and shall be closed at the underarm and set into the shoulders.

Badge Tab:

The badge tab shall be 1" wide by 2" in length and sewn on the shirt over the left breast pocket. The bottom of the badge tab shall be 7/8" above the breast pocket. The eyelets shall be centered on the tab, approximately 1 1/4" apart. Two eyelets shall be placed to allow the badge, when worn, to hang above the pocket.

Shirt Closure:

The shirt shall have a placket with snap fastener closure. The placket shall be attached to the left side of the closure and shall extend from the collar to the tail of the shirt. The placket shall be reinforced with Nomex non-woven interlining for added stiffening. Six (6) concealed female snaps will be set in the center of the placket; the right side shall have six (6) male snaps set in the center. The left side of the placket shall have five (5) decorative buttons at 24 linge and one button at 20 linge at the collar.

Collar:

The shirt shall contain a 2-piece convertible French style banded collar to enhance the appearance retention of the shirt. The collar and collar band shall be reinforced with Nomex non-woven interlining fused to the fabric for added shape retention. The top of the collar shall have a 20 linge button closure.

For Chief Officers, Captains and Lieutenant collar insignia, collars shall have one (1) eyelet or reinforced hole on each side, which shall be sewn into the center of the shirt collar, 2” from the collar tips.

Yoke:

The yoke shall extend the full width of the back to each set-in sleeve. The yoke shall be double layered and extend straight across the back.

Finishing:

All Nomex IIIA or approved substitute shirts shall be pressed and autoclaved to impart permanent press characteristics to the fabric and the garment.

Sizes and Colors

Colors	Stack Size Range
Navy	Chest 38-50, 52-58
Navy	Regular, Long

Labels:

All garments shall bear all labels mandated by the Federal Trade Commission at the date manufacture. Permanent labels shall be sewn into the inside of the garment and include the following information:

Product-specific data (date of manufacture, style number, size, lot number, origin). Warning labels (including product warnings, limitations of use, etc.).

Care and Laundering instructions.

Certifications (if applicable).

Manufacturer’s Guarantee:

Manufacturer shall guarantee that all garments shall be free from workmanship defects resulting from normal wear within one (1) year of purchase for garments laundered per manufacturer’s instructions. Apparel color shifting, or fading shall be excluded.

Sample:

Below is a sample of a “Navy” Fire Resistant Duty Uniform Shirts (Short Sleeve).

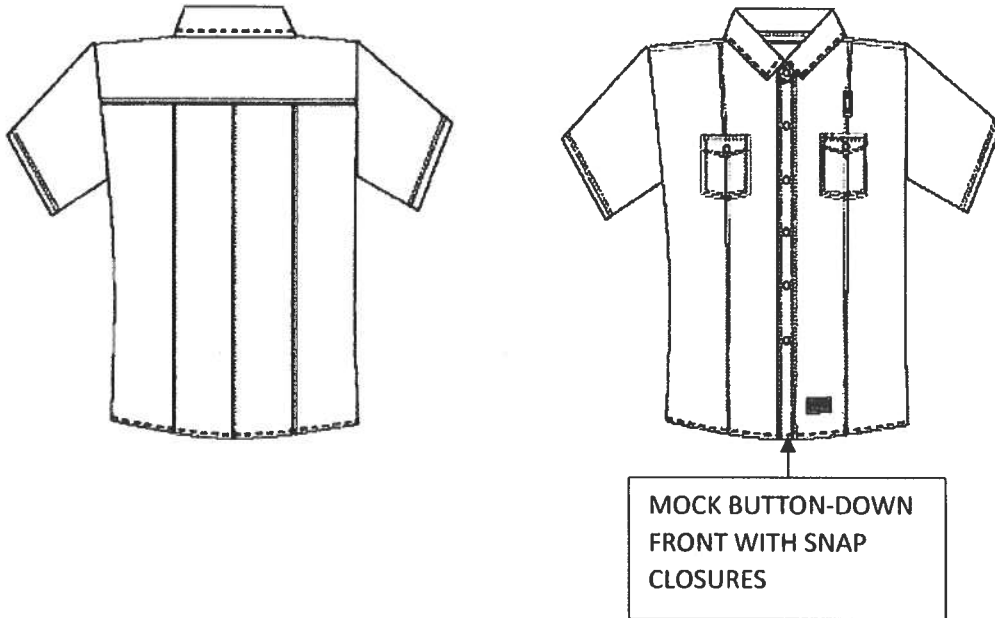

Embroidered Name:

As determined by approved purchase order.

Patches:

Attachment of one (1), 4” ARFF shoulder patch herein to be provided by Airport.

The ARFF shoulder patch shall be sewn centered on the left outer sleeve, 1” below the shoulder seam. Patches shall have heat sealed backing to secure threads in place.

Item No. 2 “Navy” Fire Resistant Duty Uniform Trousers

Men’s 7.5 oz/yd² Nomex IIIA or approved substitute Industrial and Fire Fighter Trousers
(also referred to as pants).

Fire Resistant Duty Uniform Pants shall be Navy in color.

Description

The pants shall be designed for durability with triple-stitched, felled outer seams and seat seam. The pants shall have a uniform cut with four (4) deep inverted pockets. The front pockets shall be slash dress style and the back pockets shall be welt design. The waistband shall be fully finished with belt loops and the legs permanently creased.

Certification and Compliance

Pants shall be ISO 9001 certified. Industrial and pleated fire fighter pants made from Nomex IIIA or approved substitute (7.5 oz/yd²) fabrics shall meet the performance requirements of ASTM F-1506; Standard Performance Specification for Flame Resistant and Electric Arc Rated Protective Clothing Worn by Workers Exposed to Flames and Electric Arcs, NFPA 2112; Standard on Flame-Resistant Clothing for Protection of Industrial Personnel Against Short-Duration Thermal Exposures from Fire; and NFPA 1975 Standard on Emergency Services Work Clothing Elements. These garments shall meet or exceed the requirement of OSHA Standard 1910.269: “Electric Power Generation, Transmission, and Distribution; Electrical Protective Equipment (Maintenance Standard)”, Federal Register, Volume 59, No. 20, and CAL/OSHA General Industry Safety Orders (GISO), Title 8. The pants shall be tested in accordance with Federal Test Standard 191, Method 5903.2.

Materials

The following arc ratings apply to these garments:

<u>Fabric</u>	<u>Nominal wt.</u>	<u>Arc Rating</u>
Nomex IIIA or approved substitute	7.5 oz/yd ² or approved substitute	6.6 cal/cm ² or approved substitute

Fabric and Pocketing:

The pants shall be manufactured with Nomex IIIA or approved substitute. The fabric shall be treated with a wickable finish to enhance absorbency and improve comfort. For pocketing and other internal construction fabrics shall be made from Nomex IIIA or approved substitute and shall have a minimum weight of 4½ oz/yd² or approved substitute.

Findings:

The zipper shall contain solid brass hardware (zipper teeth and chain) with a semi-automatic slide. The zipper tape shall be made from Nomex fiber or approved substitute. The thread for all seams and stitching shall be made from Nomex, Nomex III, Nomex IIIA aramid fiber, or approved substitute.

The thread size shall be 45/3 or equivalent to ensure adequate seam strength and garment integrity. The color of the thread shall match the fabric. The thread for seaming and stitching shall conform to MIL-T-43636.

The waist closure shall be a rivet button made of solid brass. The inside of the rivet button shall be separated from the skin with a layer of Nomex fabric or approved substitute.

Garment Construction:

Garments shall be constructed to maximize the wear life of the garment. Proper stitching, reinforced stress areas and the highest quality construction features shall be used. All garment parts must be properly cut to avoid puckering after laundering and to give the best appearance. All stitching must be of proper tension and size.

Stitches and Seams:

All stitching shall conform to Federal Standard 751 (FED-STD-751A). All stitch types shall be sewn with a minimum of 8 and a maximum of 10 stitches per inch. The thread tension shall be maintained to eliminate loose or tight stitching.

Front Pockets:

The pant shall have two slash type pockets sewn into the waistband, extending 9" down and having a 7" opening. The bottom of the pockets shall be reinforced with an additional layer of pocketing 2" deep at the pocket point and reinforced with bartack stitches. The edge of each pocket attached to the pant side seam shall be a minimum of 1" into the pocket and shall be reinforced with an additional layer of pant fabric for aesthetic and strength purposes.

Back Pockets:

The back pockets shall be welt construction with an opening of 5 ½" wide. The pocket shall be 7" wide and 7" deep. The top of the pocket shall set into the waistband. The welt opening shall be set 3" below the bottom of the waistband. A pocket facing of shell fabric extends ½" into the pocket to prevent visibility of the pocket material through the welt. Each side of the welt pocket openings shall be reinforced with bartack stitches. The left pocket shall have a button (size 22 or 24 ligne) and loop closure.

Zipper and Fly:

The right fly shall be made with an additional layer of Nomex fabric or approved substitute and shall be attached to the right front of the pant. The exposed edge shall be sewn to prevent unraveling. The right side of the zipper shall be set into the fly sewn through both layers of the fabric for added reinforcement and shape retention. The left side of the fly shall be fully lined internally for added reinforcement and shape retention. The left side of the zipper shall be stitched through the left pant fabric, the zipper tape and the lining.

The right and left fly shall be joined together at the base of the zipper using two (2) parallel bartack stitches that are sewn through the fly and zipper tape on both sides of the base of the zipper. The fly facing shall continue down into the crotch area to cover all metal parts of the zipper.

Crotch and Seam Assembly:

The crotch shall be formed below the fly at the intersection of the four (4) bottom panels of the pant. The pants shall be assembled in the following order: front and seat center seams, outside leg seams and inside leg seams to form the completed pant.

Finishing:

Autoclaving: All Nomex IIIA or approved substitute pants shall be pressed and autoclaved to impart permanent press characteristics to the fabric and the garment.

Leg Creases: Creases shall be pressed into the centers of the front and back of the pant legs using a hot head press. The creases shall be "lintrak" treated (i.e., treated with a special fabric adhesive) to enhance crease retention.

Colors	Stock Size Range
Navy	Waist 28-34, Inseam to 34"
	Waist 35-42, Inseam to 36"
	Waist 44-58, inseam to 36"
	No odd waist after 35"

Labels:

All garments shall bear all labels mandated by the Federal Trade Commission at the date manufacture. Permanent labels are sewn into the inside of the garment and include the following information:

Product-specific data (date of manufacture, style number, size, lot number, origin). Warning labels (including product warnings, limitations of use, etc.).

Care and laundering instructions.

Certifications (if applicable).

Manufacturer's Guarantee:

The Manufacturer shall guarantee that all garments shall be free from workmanship defects resulting from normal wear within one (1) year of purchase for garments laundered per Manufacturer's instructions. Apparel color shifting or fading shall be excluded. Garment shall be produced from a manufacturing facility with a quality system that shall be ISO 9001 certified.

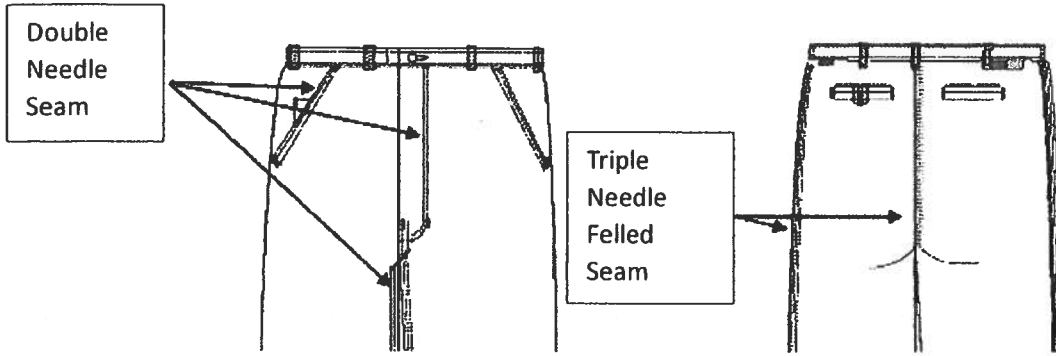

Item No. 3 “Navy” Duty Uniform Base Layer Fire Resistive T-Shirts.

The shirt shall be navy in color, made with a 5.0 oz/yd² TechT4 fabric or approved substitute, a tapered fit, and a fully-finished ribbed collar.

Certification and Compliance:

Manufacture shall be ISO 9001 certified. The garment shall meet the following performance requirements:

ASTM F-1506 specification for “Textile Materials for Wearing Apparel for Use by Electrical Workers Exposed to Momentary Electric Arc”; OSHA Standard 1910.269: “Electric Power Generation, Transmission, and Distribution”; and CAL/OSHA General Industry Safety Orders (GISO), Title 191A, Method 5903.2.

Materials:

The following arc ratings apply to these garments:

<u>Fabric</u>	<u>Nominal Wt.</u>	<u>Arc Rating</u>
TechT4 or approved substitute	5.0 oz/yd ² or approved substitute	5.8 ATPV or approved substitute

The base layer shall be manufactured with TechT4 or approved substitute knit fabric of 48% Modacrylic, 37% Lyocell, 15% Nylon.

Findings:

The thread size shall be 45/3 or equivalent to ensure adequate seam strength and garment integrity. The color of the thread shall match the fabric. The thread for seaming and stitching shall conform to MIL-T-43636.

Garment Construction:

Garments shall be constructed to maximize the wear life of the garment. Proper stitching, reinforced stress areas, and the highest quality construction features shall be used. All garment parts must be properly cut to avoid puckering after laundering and to give the best appearance. All stitching must be of proper tension and size.

Stitches and Seams:

All stitching shall conform to National Standard ASTM D-6193-97. All stitch types shall be sewn with a minimum of 8 and a maximum of 10 stitches per inch. The thread tension shall be maintained to eliminate loose or tight stitching.

Sleeves:

The sleeves shall have a hemmed cuff.

Printing:

Printing shall be done in lemon yellow colored ink, matching the existing shade used by the HFD. The logo shall be screened with a clear inking design (no running or overlapping of the ink into the design). "Flash curing" or other acceptable procedure shall be done to prevent the dark background from appearing in the printing/logo.

Warranty:

In addition to adhering to the warranty described below, the Contractor shall have warranty for silk screening for not less than one (1) year. This warranty shall cover fading, peeling, cracking, and running of the silk screen ink.

Front of Shirt:

The shirt to be provided shall have the word "FIRE", silk screened in 2" letters, centered on the front. Letters shall be outlined with 1/8" borders.

The word "FIRE" shall be silk screened in 2" letters, outlined with 1/8" borders, and centered on the back with the words "AIRCRAFT RESCUE FIREFIGHTING" DEPARTMENT OF TRANSPORTATION" "AIRPORTS DIVISION" in 5/8" letters below the word "FIRE".

Sleeve of Shirt:

A 3" stencil of the ARFF shoulder patch shall be silk screened and centered on the left outer sleeve with the bottom of the shoulder patch being 1½" from the hemline.

Stock Sizes and Colors

Colors	Stock Size Range
Navy	S, M, L, XL, 2XL, 3XL, 4XL

Labels:

All garments bear all labels mandated by the Federal Trade Commission at the date of manufacture. Permanent labels are sewn into the inside of the garment and include the following information:

Product-specific data (date of manufacture, style number, size, lot number, origin). Warning labels (including product warnings, limitations of use, etc.). Care and laundering instructions. Certifications (if applicable).

Manufacturer's Guarantee:

Manufacturer shall guarantee that all garments will be free from workmanship defects resulting from normal wear within one (1) year of purchase for garments laundered per Manufacturer's instructions. Apparel color shifting or fading shall be excluded.

Item No. 4 "Navy" Duty Uniform Jackets.

Uniform jackets shall be navy in color and include, but not be limited to the following:

Constructed entirely from a heavy duty, 65% Dacron polyester and 35% cotton twill blend or approved substitute. The fabric shall be acid-resistant. A bi-swing back for added mobility. The following jacket sizes shall be available: Small (S), Medium (M), Large (L), Extra Large (XL), Extra Extra Large (2XL), Extra Extra Extra Large (3XL) and Extra Extra Extra Extra Large (4XL).

An optional service can be selected by the ordering ARFF personnel to have a longer jacket tail length (2" or longer) and/or proportionate length sleeves for the garment. The charge for this service shall be added to the individual shirt size cost. Adding fabric to an existing garment shall not be acceptable.

The Contractor shall also have jacket liners compatible to the jackets described herein, available to purchase. The Airport will provide 75% of costs and 25% shall be at ARFF personnel expense.

Patches:

Attachment of one (1), 4", ARFF shoulder patch specified herein to be provided by Airports.

The ARFF shoulder patch shall be sewn centered on the left outer sleeve, 1" below the shoulder seam. Patches shall have heat sealed backing to secure threads in place.

Item No. 5 “Navy” Duty Uniform Cotton T-Shirts (Short Sleeve).

The furnished uniform cotton t-shirts shall be navy in color.

Constructed from fabric that is a minimum 6.0 oz., 100% cotton.

The following shirt sizes: Small (S), Medium (M), Large (L), Extra Large (XL), and Extra Extra Large (2XL), Extra Extra Extra Large (3XL), Extra Extra Extra Extra Large (4XL).

Printing:

Printing shall be done in lemon yellow colored ink, matching the existing shade used by the HFD. The logo shall be screened with a clear inking design (no running or overlapping of the ink into the design).

"Flash curing" or other acceptable procedure shall be done to prevent the dark background from appearing in the printing/logo.

Warranty:

In addition to adhering to the warranty described below, the Contractor shall warranty the silk screening for not less than one (1) year. This warranty shall cover fading, peeling, cracking, and running of the silk screen ink.

Front of Shirt:

The shirt to be provided shall have the word “FIRE”, silk screened in 2” letters, centered on the front. Letters shall be outlined with 1/8” borders.

For Lieutenants and Captains, the rank of “LIEUTENANT”, “CAPTAIN”, shall be silk screened in ¾” lettering above the letter “E” in “FIRE”.

Back of Shirt:

The word “FIRE” shall be silk screened in 2” letters, outlined with 1/8” borders, and centered on the back with the words “AIRCRAFT RESCUE FIREFIGHTING” DEPARTMENT OF TRANSPORTATION” “AIRPORTS DIVISION” in 5/8” letters below the word “FIRE”.

Sleeve of Shirt:

A 3” stencil of the ARFF shoulder patch shall be silk screened and centered on the left outer sleeve with the bottom of the shoulder patch being 1½ inch from the hemline.

Item No. 6 “Navy” Duty Uniform Cotton T-Shirts (Long Sleeve).

The furnished uniform cotton t-shirts shall be navy in color.

Constructed from fabric that is a minimum 6.0 oz., 100% cotton.

The following shirt sizes: Small (S), Medium (M), Large (L), Extra Large (XL), and Extra Extra Large (2XL), Extra Extra Extra Large (3XL).

Printing:

Printing shall be done in lemon yellow colored ink, matching the existing shade used by the HFD. The logo shall be screened with a clear inking design (no running or overlapping of the ink into the design).

"Flash curing" or other acceptable procedure shall be done to prevent the dark background from appearing in the printing/logo.

Warranty:

In addition to adhering to the warranty described below, the Contractor shall warranty the silk screening for not less than one (1) year. This warranty shall cover fading, peeling, cracking, and running of the silk screen ink.

Front of Shirt:

The shirt to be provided shall have the word “FIRE”, silk screened in 2” letters, centered on the front. Letters shall be outlined with 1/8” borders.

Back of Shirt:

The word “FIRE” shall be silk screened in 2” letters, outlined with 1/8” borders, and centered on the back with the words “AIRCRAFT RESCUE FIREFIGHTING” DEPARTMENT OF TRANSPORTATION” “AIRPORTS DIVISION” in 5/8” letters below the word “FIRE”.

Sleeve of Shirt:

A 3” stencil of the ARFF shoulder patch shall be silk screened and centered on the left outer sleeve with the bottom of the shoulder patch being 4 inches from the shoulder.

Item No. 7 “Navy” Duty Uniform Board Shorts

Board shorts shall be navy in color.

Board shorts shall include, but not be limited to the following:

Constructed from fabric that is a quick drying material, 92% polyester and 8% spandex.

A front closure that is black Velcro or approved substitute and be a minimum of 1” wide and approximately 6” long.

Four (4) enamel coated, metal eyelets for fastening by an attached 100% nylon lace, black in color, with a minimum 5/8” aglet.

A waistband measuring approximately 1½” wide.

Shorts shall have cargo pocket that has an external pocket flap. Pocket shall be a minimum 5” x 5” and shall be professionally sewn on the right leg. The pocket flap shall be provided with a minimum 1” wide Velcro or approved substitute, that is a minimum 3-1/2” long.

Shorts shall have a minimum of 4” heavy-duty elastic loop key holder, sewn into the inside of the pocket. Pocket shall have a mesh lining to drain sand.

The stitching shall be done using Navy color thread.

Size and Color:

Color	Stock Size, Length
Navy	Waist 28-54, Length: 19” or approved substitute.

Patch:

Shorts shall have an attachment of one (1), 3” ARFF patch as specified herein to be provided by the Offeror.

Patch shall be sewn on the left leg with the bottom of the patch 1 1/2” above the leg hem stitch, 1 1/2” from the left leg seam, and shall have heat sealed backing to secure threads in place.

Item No. 8 “Navy” Duty Uniform Athletic Shorts

Uniform athletic shorts shall include, but not be limited to the following:

The item supplied shall be made of a fabric that is polyester and shall be quick drying.

Shorts shall have an elastic waist band 1½” wide with a sewn-in drawstring.

Short shall have an inseam of 9” or approved substitute.

Shorts shall have two (2) side split pockets, one (1) on each of the front sides of the athletic shorts. The pocket shall have an approximately 6” slit opening. All stress points shall have bartack enforced, “Z” stitch corners.

The following sizes shall be available: Small (S), Medium (M), Large (L), Extra Large (XL), Extra Extra Large (2XL), Extra Extra Extra Large (3XL).

The stitching shall be done using Navy color thread.

Patch:

The shorts shall have attachment of one (1), 3” ARFF patch as specified herein to be provided by the Offeror.

Patch shall be sewn on the left leg with the bottom of the patch 1 1/2” above the leg hem stitch, 1 1/2” from the left leg seam, and shall have heat sealed backing to secure threads in place.

Proposal Schedule

Item No.	Description	UOM	Unit Price
1	"Navy" Fire Resistant Duty Uniform Shirts (Short Sleeve) Chest 38-58	ea	
	Manufacturer:		
	Model:		
1a	"Navy" Fire Resistant Duty Uniform Shirts (Short Sleeve) Chest 60	ea	
	Manufacturer:		
	Model:		
1c	Option for Longer Shirt Tail and Sleeves Service Charge	ea	
	Manufacturer:		
	Model:		
2	"Navy" Fire Resistant Duty Uniform Trousers Waist 28-29, Inseam to 34"	ea	
	Manufacturer:		
	Model:		
2a	"Navy" Fire Resistant Duty Uniform Trousers Waist 30-50, Inseam to 36"	ea	
	Manufacturer:		
	Model:		
2b	"Navy" Fire Resistant Duty Uniform Trousers Waist 52-60, inseam to 36"	ea	
	Manufacturer:		
	Model:		
3	"Navy" Duty Uniform Base Layer Fire Resistive T-Shirts S-3XL	ea	
	Manufacturer:		
	Model:		
3a	"Navy" Duty Uniform Base Layer Fire Resistive T-Shirts 4XL	ea	
	Manufacturer:		
	Model:		
4	"Navy" Duty Uniform Jackets ST-4XLT	ea	
	Manufacturer:		
	Model:		
5	"Navy" Duty Uniform Cotton T-Shirts (Short Sleeve) S-XL	ea	
	Manufacturer:		
	Model:		

5a	"Navy" Duty Uniform Cotton T-Shirts (Short Sleeve) 2XL	ea	
	Manufacturer:		
	Model:		
5b	"Navy" Duty Uniform Cotton T-Shirts (Short Sleeve) 3XL	ea	
	Manufacturer:		
	Model:		
5c	"Navy" Duty Uniform Cotton T-Shirts (Short Sleeve) 4XL	ea	
	Manufacturer:		
	Model:		
6	"Navy" Duty Uniform Cotton T-Shirts (Long Sleeve) S-XL	ea	
	Manufacturer:		
	Model:		
6a	"Navy" Duty Uniform Cotton T-Shirts (Long Sleeve) XXL	ea	
	Manufacturer:		
	Model:		
6b	"Navy" Duty Uniform Cotton T-Shirts (Long Sleeve) XXXL	ea	
	Manufacturer:		
	Model:		
7	"Navy" Duty Uniform Board Shorts Waist 28 - 38	ea	
	Manufacturer:		
	Model:		
7a	"Navy" Duty Uniform Board Shorts Waist 40 - 44	ea	
	Manufacturer:		
	Model:		
7b	"Navy" Duty Uniform Board Shorts Waist 46 - 50	ea	
	Manufacturer:		
	Model:		
7c	"Navy" Duty Uniform Board Shorts Waist 52 - 54	ea	
	Manufacturer:		
	Model:		
8	"Navy" Duty Uniform Athletic Shorts Waist S - XL	ea	

	Manufacturer:		
	Model:		
8a	"Navy" Duty Uniform Athletic Shorts Waist XXL	ea	
	Manufacturer:		
	Model:		
8b	"Navy" Duty Uniform Athletic Shorts Waist 3XL	ea	
	Manufacturer:		
	Model:		
	Total		

Bids shall include all applicable taxes and fees. The prices herein shall include all labor, materials, equipment and incidentals to perform all work in accordance with the project specifications.

Note 1: Bid shall include all Federal, State, County and other applicable taxes.

Note 2: The "TOTAL AMOUNT:" shall be used to determine the lowest responsible bidder.

Note 3: Bidders must complete all unit prices and amounts. Failure to do so shall be grounds for rejection of bid.

Note 4: The State reserves the right to reject any and or all Proposals and to waive any defects in the best interest of the State.